

ELECTRIC ACTUATOR

PRODUCT INSTRUCTIONS

Please read the instructions carefully before use, so that it can be used correctly.



APPEARANCE

I .Component name

- | | |
|---------------------------|---|
| 1.Position Indicator (3D) | 4.Hand wheel |
| 2.Cable gland | 5.Flange EN ISO5211 |
| 3.Actuator Top Cover | 6.Expansion unit for modulating type (torque≤80Nm only) |

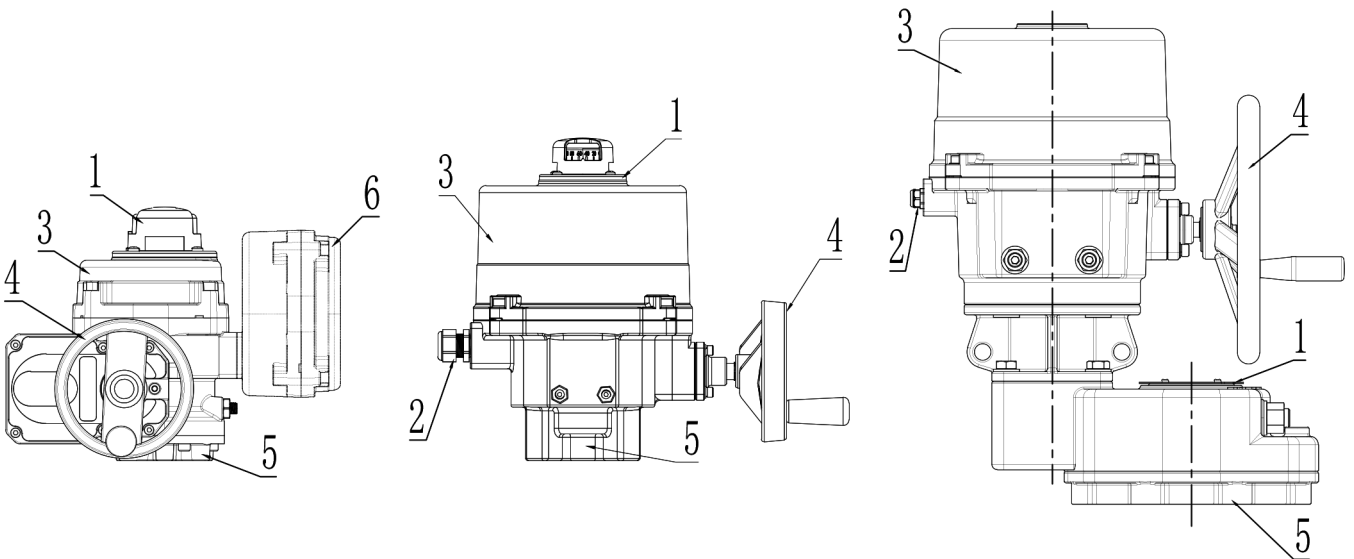

INSTALLATION

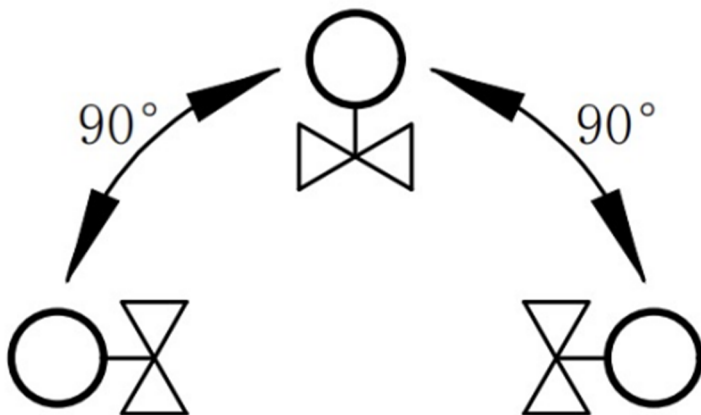

The valve should be in fully open position during local pipeline pressure testing and flushing.

VALVE MOUNTING

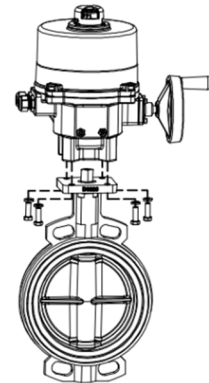
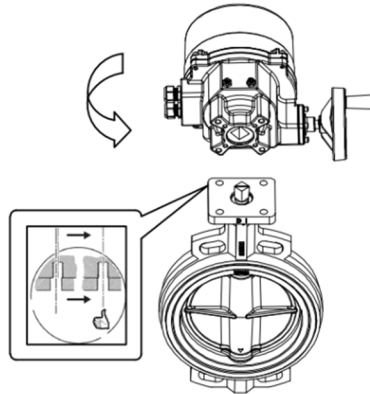
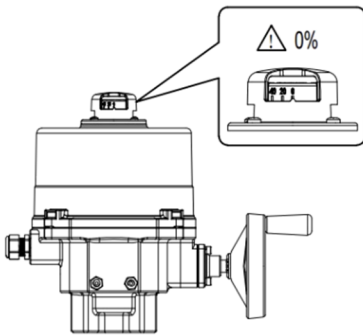
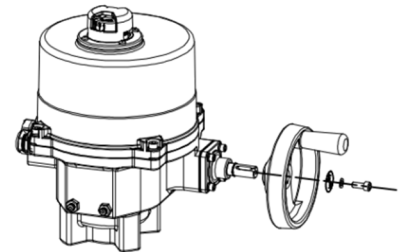
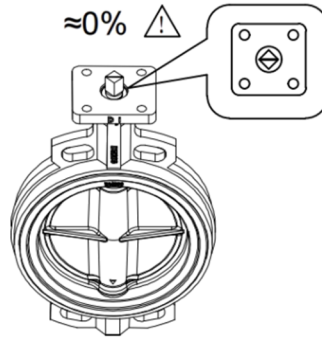
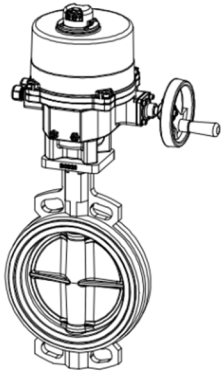

Technical Parameter

Model	Torque (Nm)	Running time (Sec./90°)	Power (VA)	Flange (ISO5211)	Adapter (mm)
HEQ1-05	50	20	48	F05/F07	11×11
HEQ1-08	80	30	48	F05/F07	14×14
HOM2-10	100	19	91	F07/F10	14×14 17×17
HOM2-20	200	39	91	F07/F10	
HOM2-30	300	39	100	F07/F10	
HOM3-40	400	29	194	F10/F12	22×22 27×27
HOM3-60	600	39	194	F10/F12	
HOM3-80	800	47	194	F10/F12	
HOM3-100	1000	47	241	F10/F12	
HOM3-130	1300	47	286	F10/F12	27×27 36×36
HOM4-170	1700	34	435	F12/F16 or F14	
HOM4-200	2000	34	495	F12/F16 or F14	
HOM4-230	2300	47	435	F12/F16 or F14	36×36 46×46
HOM4JS-350	3500	76	495	F16/F25	
HOM4JS-500	5000	136	435	F16/F25	
HOM4JS-800	8000	188	435	F16/F25	

ELECTRICAL WIRING



ATTENTION

The electrical connection of the actuator must comply with local regulations (See wiring diagram for details), and must always comply with relevant regulations and restrictions to ensure the safety of the operators and property.

MANUAL OPERATION

HEQ1-05/08	Push the hand wheel in before manual operation, and after this operation, pull the hand wheel out to avoid damage.
HOM2-4JS	No clutch mechanism, the hand wheel is always ready to work.

WIRING DIAGRAM

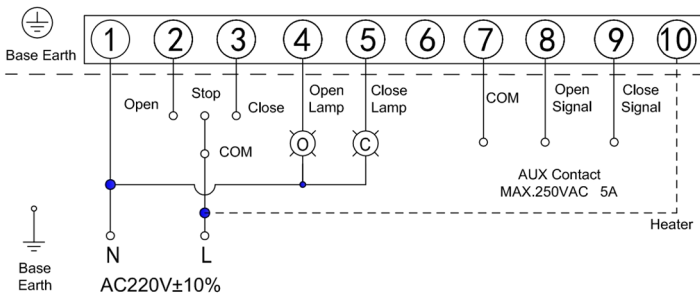

HEQ Series

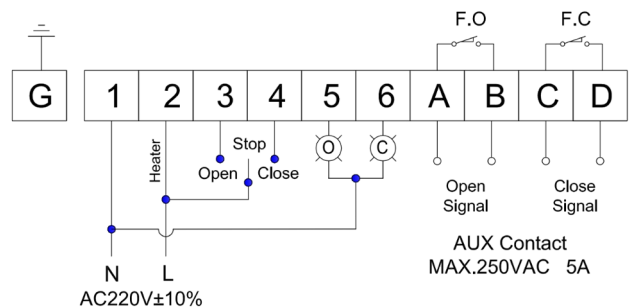

HOM Series

On-off Type

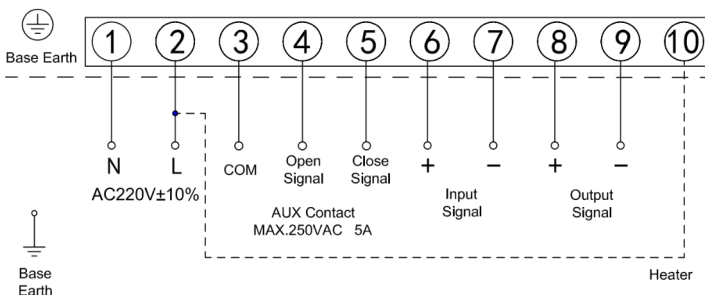

HEQ Series

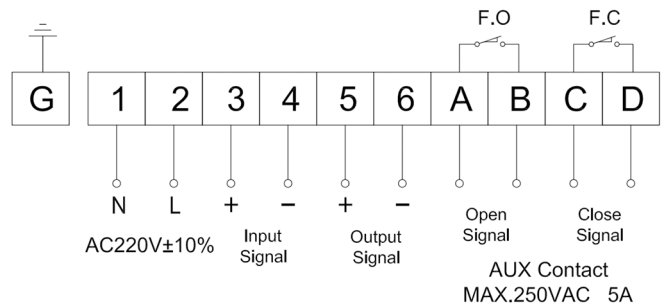

HOM Series

Modulating Type

PRODUCT SIZE PARAMETER

HEQ1 Dimension Diagram

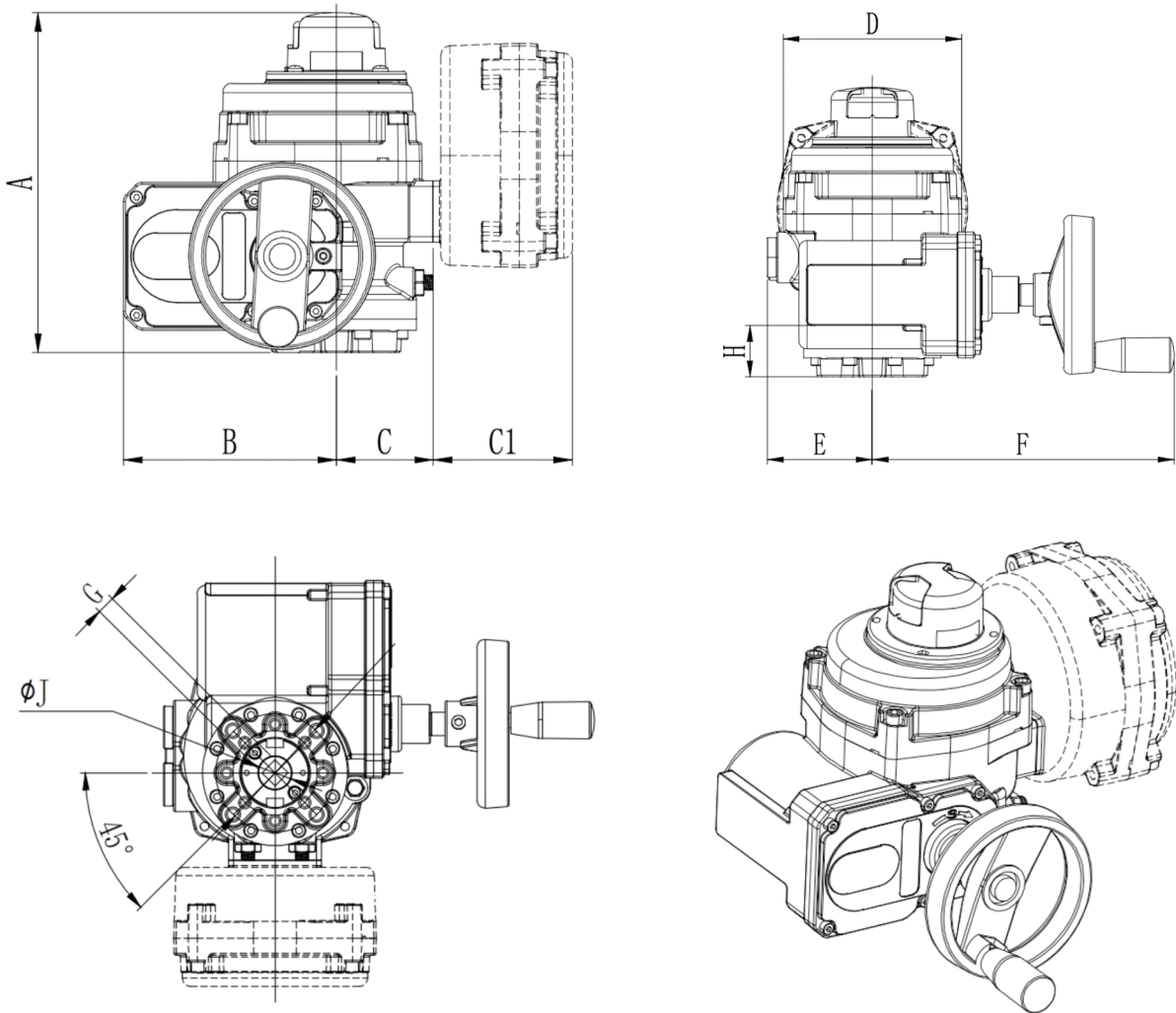

Technical Parameter

Model		A	B	C	C1	D	E	F	G	H	ϕI	J
HEQ1-05	On/off	182	114	52	/	140	94	190	11×11	30	50	4-M6
HEQ1-08	Modulating	182	114	52	75	140	94	190	14×14		70	4-M8

Notes:

C1 is length of electronic control expansion unit for modulating type, on/off type does not have this unit.

HOM2-4 Dimension Diagram

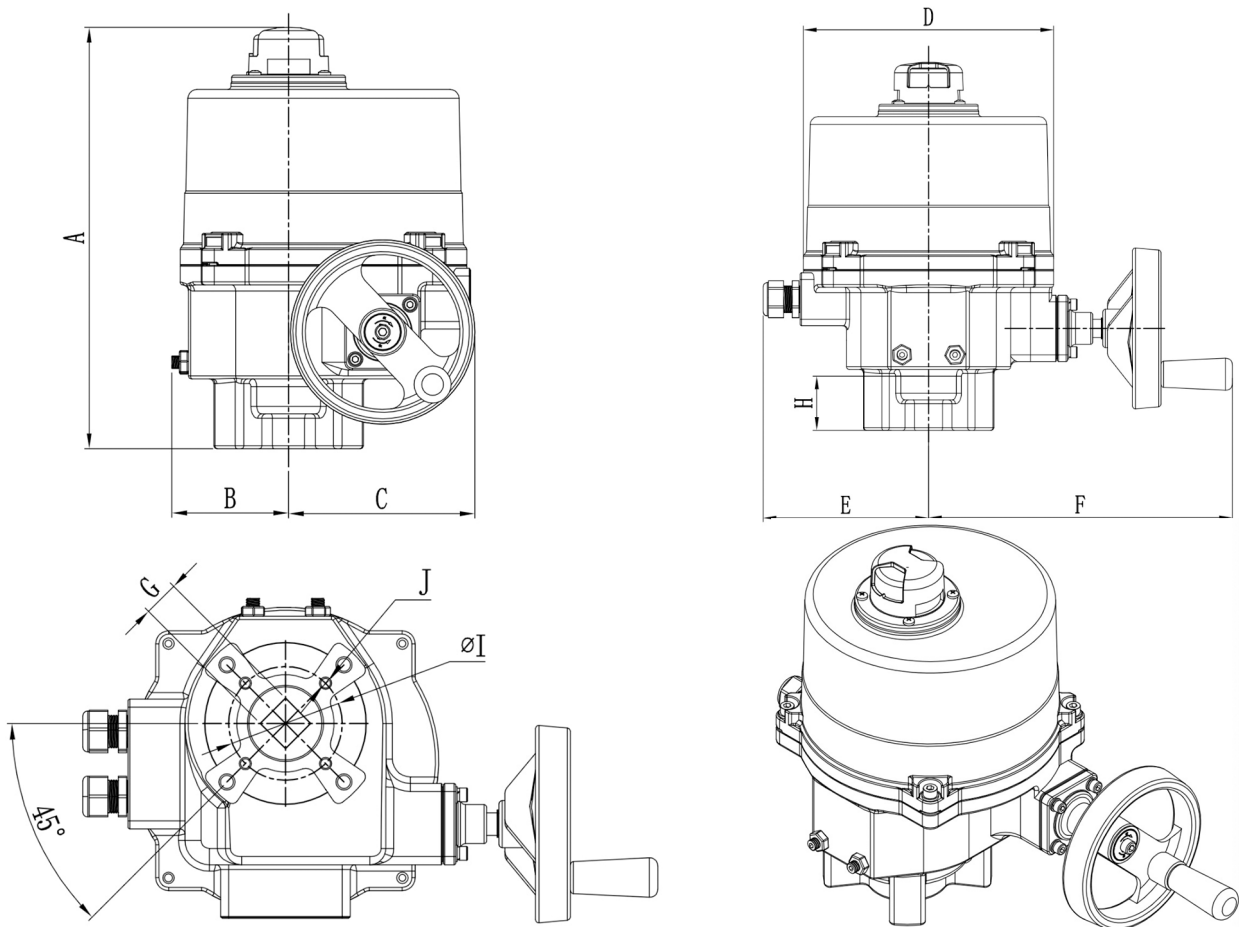

Technical Parameter

Model	A	B	C	D	E	F	G	H	φI	J
HOM2-10	278	78	125	189	125	232	14×14	35	70	4-M8
HOM2-20							17×17		102	
HOM2-30										
HOM3-40	340	105	190	232	158	290	22×22	55	102	4-M10
HOM3-60							27×27		125	4-M12
HOM3-80										
HOM3-100										
HOM3-130										
HOM4-170	390	129	245	265	165	325	27×27	65	125	4-M12
HOM4-200							36×36		140	4-M16
HOM4-230										

HOM4JS Dimension Diagram

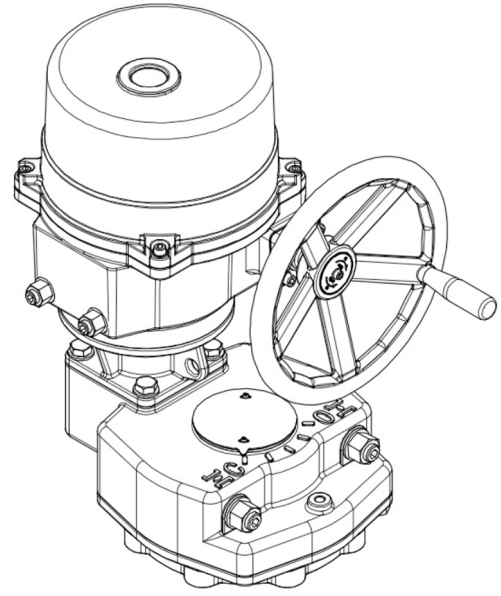
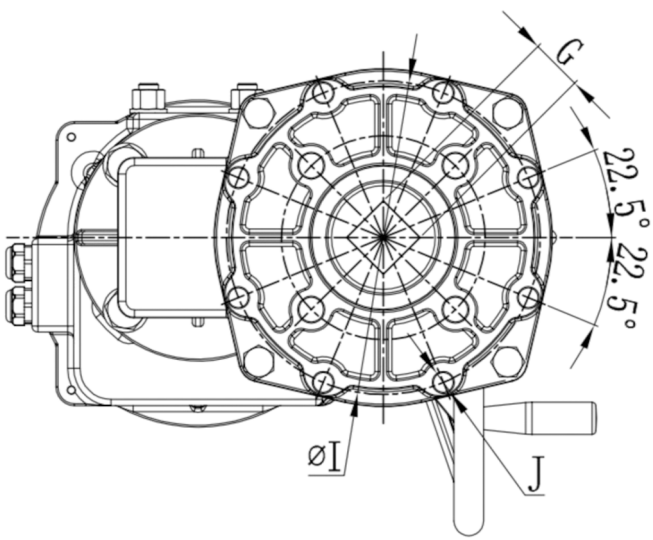
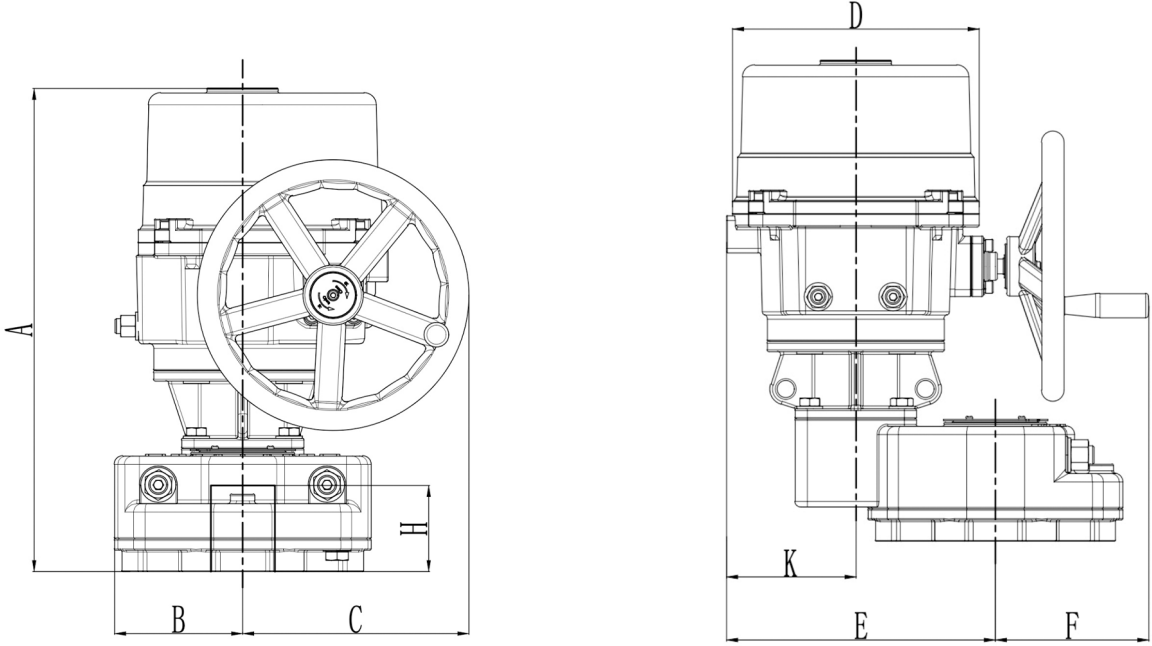

Technical Parameter

Model	A	B	C	D	E	F	G	H	φI	J
HOM4JS-350	517	137	242	265	289	165	36*36	130	165	4-M20
HOM4JS-500							46*46		254	8-M16
HOM4JS-800										

- Notes:**
1. Unit: mm.
 2. Valve shaft dimensions not showed in the table can be machined according to customer requirements, such as round shafts, double D-shafts, etc.
 3. Please contact us if special flange connection center distance needed.

Travel Cams Adjustment Instruction

When the actuator is powered on and does not reach the required position during debugging process, adjust it by inserting a flat-head screwdriver into the Cam groove. Each Cam triggers a signal switch and a travel switch successively.

Notes: Mechanical Limit screws in the corresponding direction should be loosened before adjusting the Cam.

See mechanical Limiting Adjustment instructions for details.

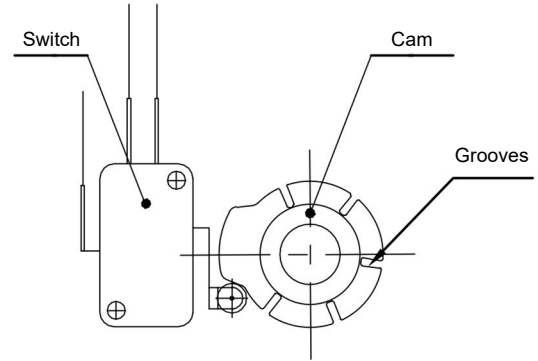
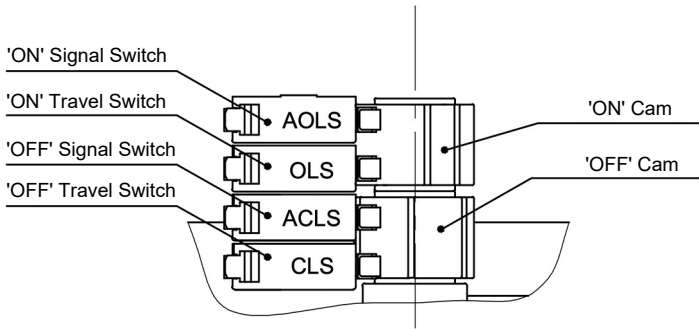

HEQ Cam layout
(Upper: Opening adjustment , Lower: Closing adjustment)

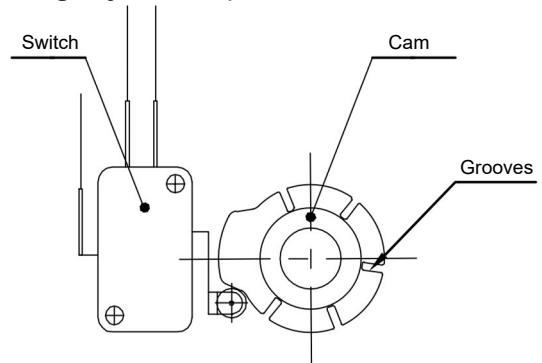
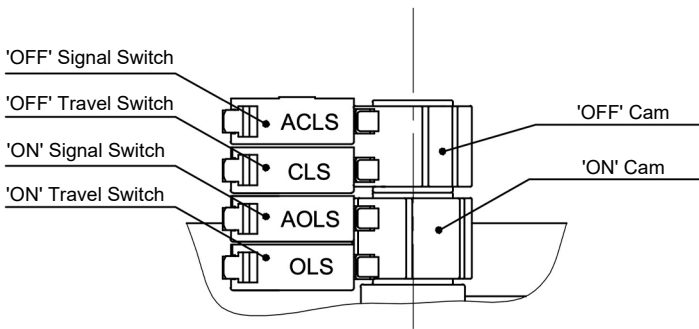

HOM Cam layout
(Upper: Closing adjustment , Down: Opening adjustment)

Mechanical Limiting Adjustment Instruction

Before adjusting the closing direction of the micro-moving CAM, loosen the locking nut on the switch limit adjustment screw, and slightly withdraw the closing limit adjustment screw with the hexagonal plate hand. After the CAM is adjusted, screw it in again. When the screw cannot be screwed, pull the closing limit adjustment screw out of half a circle in the reverse direction, and then tighten the locking nut. The setting method of open mechanical limit is the same as above.

Notes: Mechanical limit can only be done after electrical limit. Otherwise, the electric actuator will be locked-rotor, and cause motor heating or damage.

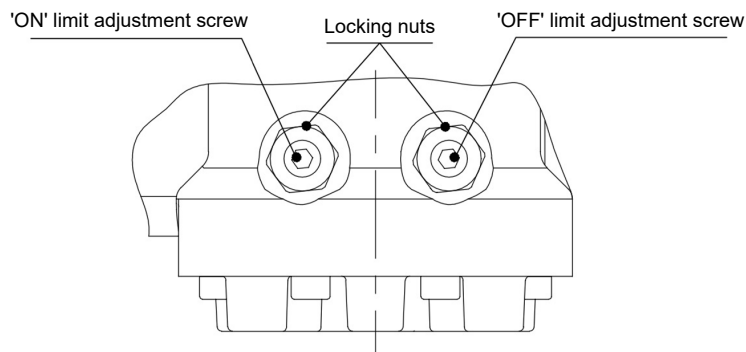

CONTROL MODULE ADJUSTMENT OPERATION DESCRIPTION

HEQ control module adjustment operation description

[Regulated signal switching operation instructions]

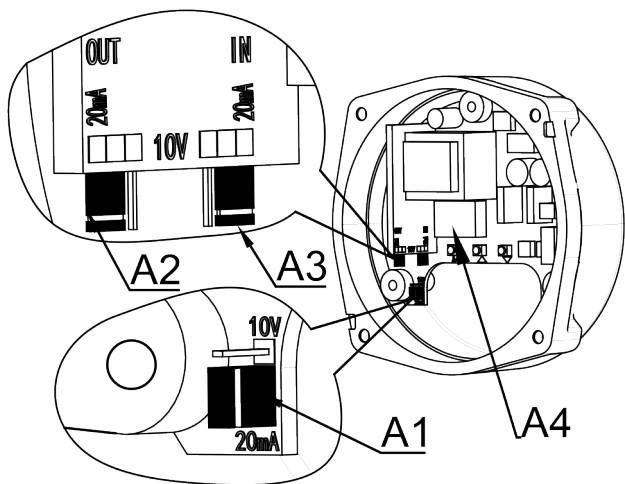
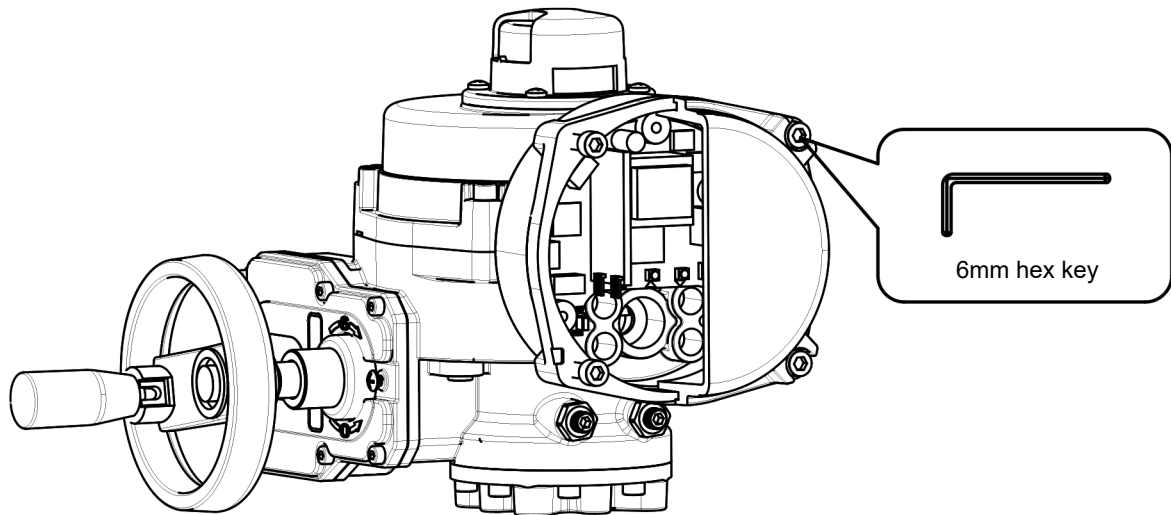

SIGNAL	A1	OUT(A2)	IN(A3)
4-20mA (Factory setting)			
2-10V			
0-20mA			
0-10V			

[Light indication information description]

Remote/Local switch button	Remote control mode Indicator status	Local control mode indicator status
<p>A/M</p>		

【 Alarm light information description 】

Alarm light indicator status A4					
Fault code	Fault information	Alarm light	Remote control light	'ON' Light	'OFF' Light
Eb	Calibration error	Flash 3 times		—	—
Ed	Valve position unchanged (locking or other causes the potentiometer not to rotate)	ON	—	Flash	Flash
EF	Valve potentiometer wiring is open or potentiometer is turned to dead zone	Flash	—	ON	ON
ES	4-20 mA control current signal is lost	ON	ON	—	—
EC	Off-direction torque or debugging is not calibrated	ON	ON	—	—
EO	Off-direction torque or debugging is not calibrated	ON	ON	—	—

【 Stroke calibration 】

LH- Automatic calibration of valve position

In remote control mode, press and hold down the "A/M" key, and then press the "▼" key for about 1 second, and release the key when the digital tube displays the letter "LH" to enter the automatic calibration state of the valve position.

The electric device moves in the off direction to touch the limit to open the light, the letter "CL" flashes twice to output the low feedback, then the actuator automatically moves in the open direction to touch the limit switch, the letter "OP" flashes twice to output the high feedback, and automatically exits after calibration.

L-off manual calibration

In local position, the electric device is moved to the off position, first press the "A/M" key, and then press the "▼" key for about 3 seconds. When the digital tube displays the letter "L", two keys are released at the same time, and the letter "CL" flashes twice to output 4mA current. The off position calibration is completed.

H- open position manual calibration

In local position, the electric device is moved to the open position, first press the "A/M" key, and then press the "▲" key for about 3 seconds. When the digital tube displays the letter "H", two keys are released at the same time, the letter "OP" flashes twice to output 20mA current, and the open position calibration is completed.

【Output current fine-tuning (Note: After entering the parameter setting, if 10s does not press the button, the program will automatically quit without saving)】

LF-4mA feedback current fine-tuning

In local position, the electric device will be operated to the off position output 4mA, while holding down the "▲" key and "▼" key for about 3 seconds, and release two keys when the digital tube displays the letter "LF" to enter the 4mA feedback current fine-tuning state. Short press "▲" key current increases, short press "▼" key current decreases; When the output current is adjusted to meet the requirements, press the "▲" key and "▼" key at the same time for about 3 seconds, the position light and the position light are on at the same time, release the two keys, and "LF" flashes twice to indicate that the fine-tuning of 4mA feedback current is completed.

HF-20mA feedback current fine-tuning

In local position, move the actuator to the open position output 20mA, while holding down the "▲" key and "▼" key for about 3 seconds, and release two keys when the digital tube displays the letter "HF" to enter the 20mA feedback current fine-tuning state. Short press "▲" key current increases, short press "▼" key current decreases; When the output current is adjusted to meet the requirements, press the "▲" key and "▼" key at the same time for about 3 seconds, the position light and the position light are lit at the same time, release the two keys, and "HF" flashes twice to indicate that the 20mA feedback current is fine-tuned.

[Advanced Settings]

Off signal status settings (need to be operated in remote control mode)

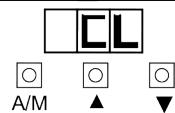
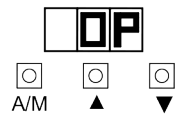
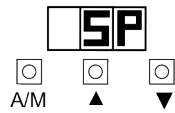
Off signal condition	Setting method	Setting success screen
Off signal all off	Press the "▼" button for 10 seconds	
The break signal is all on	Press the "▲" button for 10 seconds	
Break signal holding (factory setting)	Also press "▼" And "▲" key for 10 seconds	

Control input signal calibration (need to be operated in local control mode)

When calibrating the zero signal, confirm that the zero signal has been input.

When the full position signal is calibrated, confirm that the full position signal has been entered.

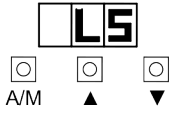
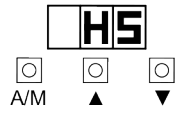
Input signal calibration	Zero input signal calibration	Full input signal calibration
Setting method	Simultaneously press "A/M" And "▼" key for 10 seconds	Simultaneously press "A/M" And "▲" key for 10 seconds
Setting success screen		

CU- Positive and negative action (need to be operated in local control mode)

Positive action: 4mA -- off (feedback signal 4mA), 20mA -- on (feedback signal 20mA);

Negative action: 4mA -- on (feedback signal 20mA), 20mA -- off (feedback signal 4mA);

Press the "▲" key and "▼" key for about 10 seconds at the same time, and release two keys when the letter "CU" is displayed on the digital tube to enter the positive and negative Settings. Press the "▲" key and "▼" key to switch, "off light" represents the positive effect, "on light" represents the reverse effect, at the same time press the "▲" key and "▼" key for about 3 seconds, the on light and off light at the same time light up the release button, "CU" flashing twice indicates that the positive and negative settings are completed.

CF- Off direction (need to be operated in local control mode)

Press the "▲" key and "▼" key at the same time for about 20 seconds, and release two keys when the letter "CF" is displayed to enter the closing direction setting. "Off" indicates clockwise, "On" indicates counterclockwise. Press the "▲" key or "▼" key to switch. Press the "▲" and "▼" keys for about 3 seconds, and the release button will be lit at the same time with the off light and on light. The "CF" flash twice to indicate that the closing direction is set.

HOM Control module main technical and parameter

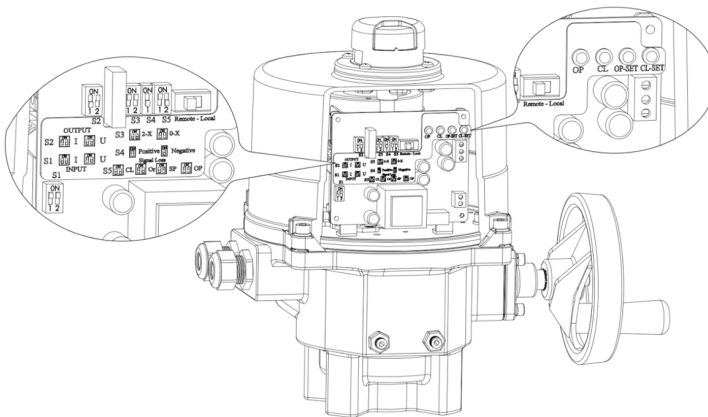

- Input signal failure judgment protection processing function
- Local manual button operation switch function
- Potentiometer middle position identification, failure alarm function
- Dead zone, position & negative action setting according to real situations
- Free selection of input and output signals :4-20mA, 0-20mA, 2-10V, 0-10V(dip switch selection)
- Input channel impedance :150Q(current); ≥400KQ(voltage)
- Resistance for current output: ≤600Q
- Hysteresis :≤0.5s

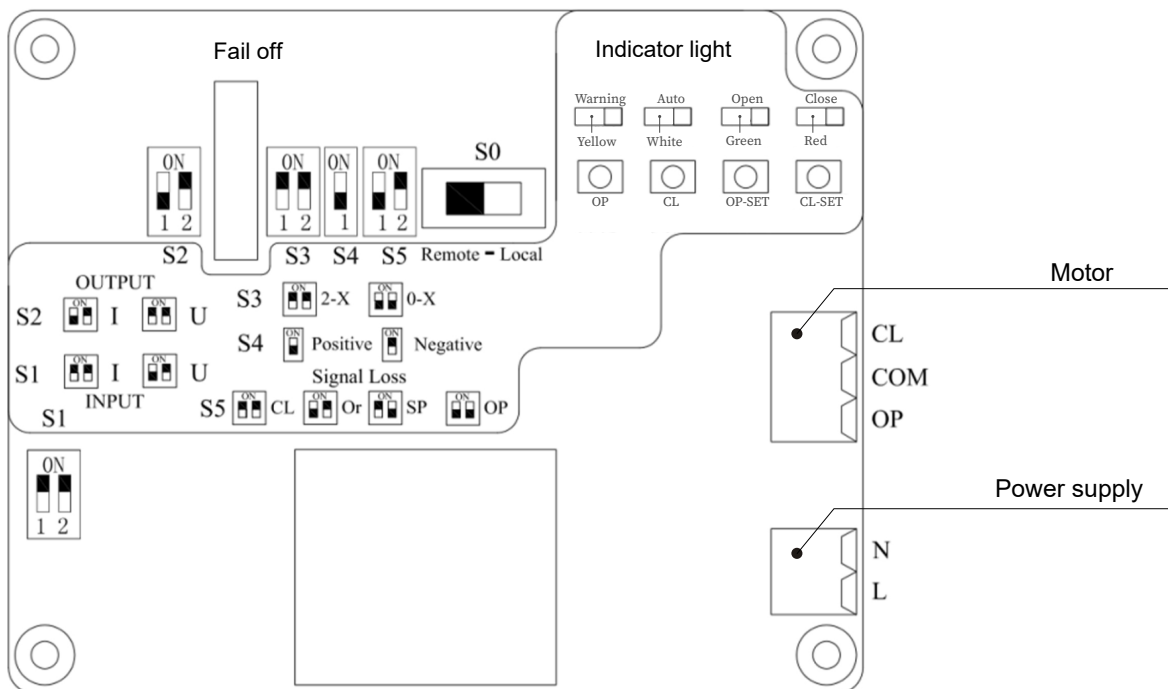

Dip Switch Meaning and Status

The dip switch can only be set on the status of 'Local' control)

Selection of input signal mode (S1)

Accomplished by dip switch S1 with 2 modes: Voltage Mode and Current Mode. See details as below:



Input Signal (Ex-factory Setting)
(4-20mA or 0-20mA current mode)



Input Signal
(2-10V or 0-10V voltage mode)

Selection of output signal mode (S2)

Accomplished by dip switch S1 with 2 modes: Voltage Mode and Current Mode. See details as below:



Output Signal (Ex-Factory Setting)
(4-20mA or 0-20mA current mode)



Output Signal
(2-10V or 0-10V voltage mode)

Selection of lower limit of ratio signal (S3)

Accomplished by dip switch S3 with 2 modes: 4mA/2V lower limit or 0mA /0V lower limit. See details as below:



Ratio signal lower limit
(Ex-Factory Setting)
(4mA/2V)



Ratio signal lower limit
(0mA/0V)

Setting of auto control of positive and negative action (S4)



Positive Action (Ex-Factory Setting)
4mA(0V) — Fully close
20mA(10V) — Fully open



Negative action
4mA(0V) — Fully open
20mA(10V) — Fully close

Valve position setting after control signal failure(S5)

When control signal is not connected, electric actuator will take it as signal failure. At this time, the indicator lights 'white' and 'yellow' are both on; actions can be selected: 'stop', 'fully open' and 'fully closed'. The selection is realized by dip switch S5. The corresponding relationship with valve position is shown in the figure below:



'Fully Close'



or



'The last position'
(Ex-Factory Setting)



'Fully Open'

III. Setting method

【Control mode switch】

Two status of control module: 'Local' and 'Remote', selected by dip switch 'S0' on the control board.



- (1) Switch S0 to 'remote' position, white indicator light lights up, electric actuator enters remote analog signal control mode.
- (2) When the switch S0 is in the "local" position, the indicator "white" light is off, and the valve electric device can be operated manually and set parameters.

【Manual operation of the electric actuator】

- (1) Press the 'ON' button on the control board, the electric actuator runs to open the valve. Release the button, then it stops. When the button was pressed for more than 3 seconds, the actuator keeps opening the valve until the opening limit disconnected or 'OFF' button is pressed.
- (2) Press the 'OFF' button, the electric actuator runs to close the valve. Release the button, the actuator stops. When press the button for more than 3 seconds, the valve kept closing, until the closing limit disconnected or the 'ON' button pressed.

Notes:

- (1) When electric actuator is closing position with closing limit disconnected, the red indicator light lights up.
- (2) When electric actuator is opening position with opening limit disconnected, the green indicator light lights up.

【 Setting of the fully open and fully close position of electric actuator 】 (No requirement for order)

Travel limit switches should be set up before the setting. Make sure Potentiometer position and opening and closing directions are correct.

Travel calibration

- a. Turn the dip switch 'S0' to 'Remote' position.
- b. In remote control mode, press the 'OFF Calibration' or 'ON Calibration' button for about 3 seconds, when both the 'red' and 'green' lights are lit up, release the button to enter the automatic valve position calibration state.
- c. The actuator turn to the close direction to reach the limit switch, and the 'red' light flashes twice to output feedback of the low signal. Then, the actuator automatically moves in the open direction to open the limit switch, and the 'green' light flashes twice to output feedback of the high signal. After Calibration completed automatically exit.

Fully open position calibration

- a. Turn the dip switch 'S0' to the 'local' position.
- b. Turn the electric actuator to fully open position, press the 'ON Calibration' button for 3s, when the green light is lit, release the button, green light flashes twice to output feedback of high signal, setting is done.

Fully close position calibration

- a. Turn the dip switch 'S0' to the 'local' position.
- b. Turn the electric actuator to fully close position, press the 'OFF Calibration' button for 3s, when the red light is lit, release the button, red light flashes twice to output feedback of low signal, setting is done.

[Control mode switch]

The control boards have passed standard signal calibration before Ex- factory, so no user calibration is required. If re-calibration is required during on-site use, please follow the operation methods below:

Calibration of output signal

● Slight debugging of low signal

Please follow the following steps to adjust the output signal when needed:

- a. Connect a current or voltage display instrument to the output terminal, according to the position of the dip switch 'S2'.
- b. Turn the dip switch 'S0' to the 'local' position.
- c. On site, drive the actuator to the OFF position to output 0-4mA or 0V signal. Press and hold the 'OFF Calibration' button for 2 seconds, and simultaneously press the 'OFF' button for about 3 seconds. Release both buttons when the red light is on for the first time. At this time, the 'red' light flashes to enter the feedback low signal slight debugging status. Short press the 'ON' button to increase current, short press the 'OFF' button to decrease current; After adjusting the output current to meet the requirements, hold down the 'OFF Calibration' button and the 'ON Calibration' button for about 3 seconds. The 'red' and 'green' lights will light up simultaneously and release the two buttons. The 'red' light will flash twice to indicate that the feedback low signal adjusting is completed.

● Slight debugging of high signal

Please follow the following steps to adjust the feedback signal when needed:

- a. Connect a current or voltage display instrument to the output terminal, according to the position of the dip switch 'S2'.
- b. Turn the dip switch 'S0' to the 'local' position.
- c. On site, drive the actuator to the ON position to output 20mA or 10V signal. Press and hold the 'ON Calibration' button for 2 seconds, and simultaneously press the 'ON' button for about 3 seconds. Release both buttons when the red light is on for the first time. At this time, the 'green' light flashes to enter the feedback high signal slight adjustment status. Short press the 'ON' button to increase current, short press the 'OFF' button to decrease current; After adjusting the output current to meet the requirements, hold down the 'OFF Calibration' button and the 'ON Calibration' button for about 3 seconds. The 'red' and 'green' lights will light up simultaneously and release the two buttons. The 'green' light will flash twice to indicate that the feedback high signal adjusting is completed.

Calibration of input signal

● Calibration of low signal

- a. Connect a low signal of 0/4mA or 0V/1V according to the position of dip switch 'S1', pay attention to the polarity, wrong connection is not allowed.
- b. Turn the dip switch 'S0' to the 'local' position.
- c. Press 'OFF Calibration' for 2s and at the same time press 'OFF' button for 10s, when the red light flash for second time, release the buttons, then the red light flashes twice, low signal calibration is done.

Notes: When the control current is less than 3mA or bigger than 5mA, the 'white' and 'yellow' lights will flash three times simultaneously during storage due to exceeding the calibration range, indicating a calibration error.

● Calibration of high signal

- a. Connect 20mA or 10V signal according to the position of dip switch 'S1', pay attention to the polarity, wrong connection is not allowed.
- b. Turn the dip switch 'S0' to the 'local' position.
- c. Press 'ON Calibration' for 2s and at the same time press 'ON' button for 10s, when the green light turn on for second time, release the buttons, then the green light flashes twice, high signal calibration is done.

Notes: When the control current is less than 18mA or bigger than 22mA, the 'white' and 'yellow' lights will flash three times simultaneously during storage due to exceeding the calibration range, indicating calibration error.

[Setting of adjusting dead band] (default-1%)

- a. Turn the dip switch 'S0' to the 'local' position.
- b. Press the 'OFF Calibration' and 'ON Calibration' buttons for 3s, release the buttons when the red and green light lit at same time, enter dead band setting status. Short press 'ON' button, dead band increase, short press 'OFF' button, it decrease. Red light is on --- 1%, Green light is on --- 2%, Green and red lights are on --- 3%, Red and green lights flash alternately --- Dead band adaptation. After reaching to adjustment of the dead band, press 'OFF Calibration' and 'ON Calibration' for 3s, green and red light lit then release the buttons. The corresponding light flashes twice to indicate that the dead zone setting is completed. 60 seconds no operation or unplug switch S0 hit the "remote control" position to exit this setting.

[Setting of closing direction] (default-clock wise)

- a. Turn the dip switch 'S0' to the 'local' position.
- b. Press the 'OFF Calibration' and 'ON Calibration' buttons for 10s. Release the buttons when the red and green light lit for the second time to enter closing direction setting status. Short press 'ON' or 'OFF' button to change close direction. Red light is on --- Close the valve clockwise, Green light is on --- Close the valve anti-clockwise. When adjust to the required closing direction, press 'OFF Calibration' and 'ON Calibration' at the same time for 3s, green and red light lit then release the buttons. The corresponding light flashes twice to indicate that the setting is completed. 60 seconds no operation or unplug switch S0 hit the "remote control" position to exit this setting.

[Setting of locked-rotor time]

- a. Turn the dip switch 'S0' to the 'local' position.
- b. Press the 'OFF Calibration' and 'ON Calibration' buttons for 15s. Release the buttons when the red and green light lit for the third time and the yellow light flashes to enter locked-rotor time setting status. Short press 'ON' button, locked-rotor time increase, short press 'OFF' button, it decrease. Red light is on --- 10s (Ex-factory Setting), Green light is on --- 15s, the two lights lit at the same time --- 20s. When adjust to the required locked-rotor time, press 'OFF Calibration' and 'ON Calibration' at the same time for 3s, green and red light lit then release the buttons. The corresponding light flashes twice to indicate that the setting is completed.

HOM CONTROL MODULE TROUBLE SHOOTING

Status of Indicator Lights				Possible Fault and Reason	Countermeasures
Alarm light	Remote Control Light	'ON' Light	'OFF' Light		
No Light on				No power connect, module failure	Check the power supply, replace module
Flash 3 times		—	—	Proportional calibration error	Check the input signal value and connections of positive and negative poles
Flash	Local light off /remote light on	ON	ON	Open circuit in the wiring of the valve position potentiometer or potentiometer turns to dead band	Check the potentiometer lead wire or replace the potentiometer
ON		Flash	Flash	The valve position remains unchanged (the potentiometer does not rotate due to locked-rotor or other reasons)	Check whether the on/off cam, valve, or electric actuator is stuck, and check if the motor is damaged
ON	ON	—	—	4-20mA or 1-10V control signal loss	Check the input signal value and connections of positive and negative poles
Flash	Local light off /remote light on	Flash	—	Open direction over torque	Check whether the open torque switch or wiring is abnormally disconnected
Flash		—	Flash	Close direction over torque	Check the close torque switch or wiring is abnormally and disconnected

